

HV Fan Range

High Efficiency Belt Drive Fans



Features & Benefits

The Hydor HV Belt Drive fan unit is specifically designed to ventilate larger buildings on the dairy farm, such as cow cubicle housing, where substantial amounts of air are moved at low pressure with minimal energy consumption.

The HV range is available in four sizes 800mm, 1000mm, 1250mm and 2000mm diameter, each with single or three phase motors and the option of louvres and guards. This powerful fan produces air volumes up to 20m³/s.

Constructed from galvanised steel with a specially designed stainless steel impeller, these fans are extremely hard wearing and robust in application. The drive mechanism includes sealed for life maintenance free ball bearings, which means low noise and vibration levels.

The HV range is available in four variations for either wall mounting with shutters, suspension mounting from roof space or floor mounting with wheels.

The HV Range includes a centrifugal operated back draught shutter or an automatic louvre shutter model. Units are supplied fully assembled complete with standard safety guards.

Features & Benefits



- A crossed steel framework with the fan hub positioned centrally. Fan blades and pulley are located on opposite sides, improving load balancing, thereby increasing bearing and fan life.

- The belt is from reinforced rubber which is easily replaced locally. Belt tensioning can be undertaken without removing the guards by using two bolts on the fan casing.

- Easy access to the motor for servicing and maintenance.



- The impeller comprises of six self-cleaning blades constructed from 304 stainless steel. The aerodynamic blade design ensures high volume displacement at low blade pressure.

- Fan housing is manufactured from galvanised sheet steel, corrosion resistant for durability and longevity.

- Each fan is fitted with a mesh safety guard either side of the unit.

- The heavy duty construction of the louvres prevents the overlapping slats from vibrating at high air flow. When not in operation, heat loss is reduced by the louvres closing automatically. Air delivery normally lost due to dirty shutters or to shutters remaining open is eliminated.



- Extract stale and humid air.

- The louvres are opened by a centrifugal mechanism; which means that once opened, the louvres do not sap the performance of the fan.

- Component spares are usually available from stock.

- 12 months product warranty.



Dimensional Data

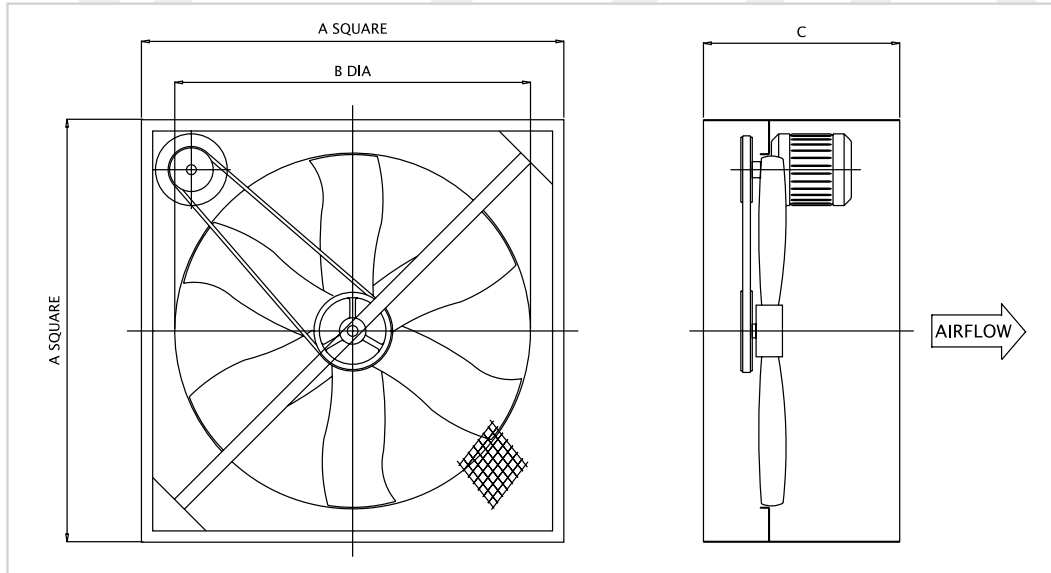

Product Code	Propeller Aperture (B)	Width (A)	Height (A)	Depth fan case only (C)	Depth inc Louvre	Depth inc Louvre & Guard	Weight (kg)	Weight inc Louvre (kg)
HV800	800	960	960	330	405	470	32	44
HV1000	1000	1150	1150	330	405	470	40	50
HV1250 (1.1kW)	1250	1380	1380	330	405	470	50	70
HV1250 H (1.5kW)	1250	1380	1380	330	405	470	52	72
HV2000	1760	1930	1930	450	450	515	75	100

N.B. All Dimensions are expressed in millimeters

Performance & Electrical Data

Product Code	Airflow m ³ /s @ Static Pressure Pa.						Speed (r/min)	Motor Electrical Data 220-240V/1Ph/50Hz			Sound Level dBA @ 3m	Weight (kg)
	0	20	40	60	80	100		Power Watts	FL Amps	Start Amps		
HV800	4.588	4.091	3.589	2.840	-	-	630	550	4.0	11.9	58	44
HV1000	7.096	6.447	5.550	4.296	3.139	1.827	520	750	5.4	14.9	59	50
HV1250 (1.1kW)	11.002	9.578	8.030	6.190	4.028	-	400	1100	7.2	25.7	60	70
HV1250 H (1.5kW)	12.104	10.863	9.465	7.866	5.746	3.189	440	1500	8.4	29.5	63	72
HV2000	20.137	16.539	12.970	7.639	-	-	280	1500	10.0	35.0	59	100

Product Code	Airflow m ³ /s @ Static Pressure Pa.						Speed (r/min)	Motor Electrical Data 400/3Ph/50Hz			Sound Level dBA @ 3m	Weight (kg)
	0	20	40	60	80	100		Power Watts	FL Amps	Start Amps		
HV800	4.588	4.091	3.589	2.840	-	-	630	550	1.65	4.95	58	44
HV1000	7.096	6.447	5.550	4.296	3.139	1.827	520	750	2.60	7.80	59	50
HV1250 (1.1kW)	11.002	9.578	8.030	6.190	4.028	-	400	1100	2.89	8.70	60	70
HV1250 H (1.5kW)	12.104	10.863	9.465	7.866	5.746	3.189	440	1500	3.20	9.60	63	72
HV2000	20.137	16.539	12.970	7.639	-	-	280	1500	3.80	12.5	59	100

Note: Motor electrical data is approximate, as it varies from one motor manufacturer to another

Accessories



- Louvre-side guard.
- 1 m flying lead.



- Full range of both automatic and manual infinitely variable or stepped transformer type controls.